

(No Model.)

W. MIDDLEDITCH.
LATHE ATTACHMENT.

No. 332,817.

Patented Dec. 22, 1885.

Fig. 1.

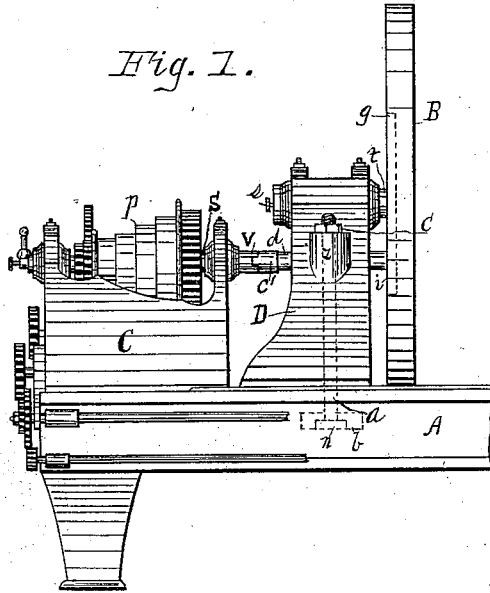

Fig. 2.

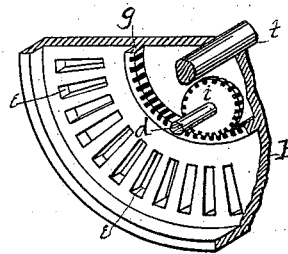
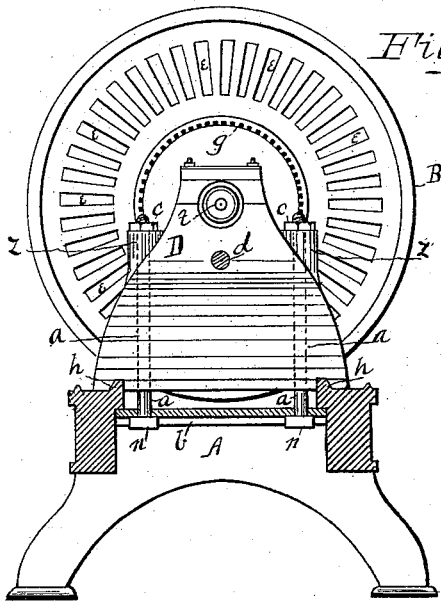

Fig. 3.

WITNESSES:

C. A. Preston,
C. W. Russell.

INVENTOR:

Walter Middleditch
By
Roscoe B. Wheeler
Att'y

UNITED STATES PATENT OFFICE.

WALTER MIDDLEDITCH, OF DETROIT, MICHIGAN.

LATHE ATTACHMENT.

SPECIFICATION forming part of Letters Patent No. 332,817, dated December 22, 1885.

Application filed May 25, 1885. Serial No. 166,578. (No model.)

To all whom it may concern:

Be it known that I, WALTER MIDDLEDITCH, a citizen of the United States, residing at Detroit, in the county of Wayne and State of Michigan, have invented certain new and useful Improvements in Lathe Attachments; and I do declare the following to be a full, clear, and exact description of the invention, such as will enable others skilled in the art to which it appertains to make and use the same, reference being had to the accompanying drawings, and to the letters and figures of reference marked thereon, which form a part of this specification.

My present invention is designed as a portable attachment for metal-working lathes, for the purpose of enabling the operator to do the work of a large lathe upon a small one at a slight expense, requiring but a short time to connect the attachment for doing the work, as hereinafter set forth.

My invention consists in a suitable support carrying a face-plate upon an independent bearing at an elevation to the drive-shaft, said face-plate being driven by means of a coupling with the free end of the spindle of a lathe carrying the common cone of pulleys, as hereinafter set forth, and pointed out in the claims.

In the drawings forming a part of this specification, Figure 1 is a front elevation of my invention attached to an ordinary iron lathe. Fig. 2 is a rear elevation, part in section. Fig. 3 is a detail in perspective broken away.

A represents the body of an ordinary lathe; C, the hood or guard over the common cone of pulleys, P, and D is a saddle or support, which is cast hollow, having recesses at the base fitting over the inner way-bearings, *h h*, of the lathe-bed, as shown in Fig. 2.

z z are lugs cast upon the saddle. Through said lugs I pass the bolts *a a*, the heads *n n* fitting within the slot of the tie-plate *b*, and by tightening the nuts *c c* the saddle or support D is firmly bound to the lathe-bed.

Journalled within the saddle in axial line with the common spindle, S, of the lathe is a driving-shaft, *d*, carrying the pinion *i* at one end and the clutch-coupling *c'* at the other end which engages with a like coupling, *v*. The

coupling *v* is provided with an internal screw-threaded portion (not shown) screwing upon the free end of the lathe-spindle S, occupying the position of the ordinary face-plate of a lathe, said face-plate being removed when this attachment is put on. I journal at an elevation vertically over the drive-shaft *d* an independent shaft, *t*, carrying an enlarged face-plate, B, as shown in Figs. 1 and 2. The pinion *i* of the drive-shaft engages with the internal gear, *g*, on the back of the face-plate B, as clearly shown in Fig. 3.

s is a set-screw working against the end of the shaft *t*, to prevent the back of the face-plate from crowding upon the face of the pinion *i*. By coupling the shaft *d* in axial line with the spindle S of the lathe, the supplemental face-plate is driven, the speed being regulated by the shifting of the drive-belt upon the cone of pulleys, as is common. The face-plate B is provided with the usual openings, *e*, through which pass bolts for the purpose of securing the material to be turned to the face-plate.

It will be observed from the foregoing that with an ordinary-sized lathe I am enabled to swing a wheel upon the face-plate B that could not be handled upon the ordinary face-plate of a lathe; that by using this attachment the face of a wheel of large diameter may be turned off readily, thus saving the cost of purchasing a large lathe to do work of this class, as is now common.

To remove the attachment, the nuts *c c* are loosened and the bolts *a a* are removed, when the support D may be moved to the right sufficiently to draw the couplings *v c'* apart, when said rest or support and its face-plate may be lifted from the lathe. The coupling *v* is unscrewed from the spindle S. The ordinary face-plate is then placed upon said spindle, and the lathe is ready for its usual work.

Having thus fully set forth my present invention, what I claim as new, and desire to secure by Letters Patent, is—

1. The combination, with the support mounted upon the frame of a lathe, and the means for securing said support to said lathe, of a face-plate, its shaft journalled in said support at an elevation to the drive-shaft, and its gear adapted to engage with the pinion of the drive-

shaft, said pinion and the drive-shaft journaled in said support and adapted to be coupled in axial line with the spindle of a lathe, for the purposes set forth.

5 2. In combination with the body of a lathe, a support mounted thereon, carrying a face-plate upon a shaft journaled in said support at an elevation to the spindle, and means,

substantially as set forth, for driving said face-plate. 10

In testimony whereof I affix my signature in presence of two witnesses.

WALTER MIDDLEDITCH.

Witnesses:

R. B. WHEELER,

B. S. WHEELER.